



九齊科技股份有限公司
Nyquest Technology Co., Ltd.

DATA SHEET

NY9M012A

Single Channel 1.2A Motor Driver

SKYTECH
ELECTRONIC

Version 1.2

May 15, 2015

NYQUEST TECHNOLOGY CO. reserves the right to change this document without prior notice. Information provided by NYQUEST is believed to be accurate and reliable. However, NYQUEST makes no warranty for any errors which may appear in this document. Contact NYQUEST to obtain the latest version of device specifications before placing your orders. No responsibility is assumed by NYQUEST for any infringement of patent or other rights of third parties which may result from its use. In addition, NYQUEST products are not authorized for use as critical components in life support devices/systems or aviation devices/systems, where a malfunction or failure of the product may reasonably be expected to result in significant injury to the user, without the express written approval of NYQUEST.

published by WWW.SKYTECH.IR

Revision History

<i>Version</i>	<i>Date</i>	<i>Description</i>	<i>Modified Page</i>
1.0	2014/11/26	New release.	-
1.1	2014/12/04	Update DC Characteristics.	6
1.2	2015/05/15	Update DC Characteristics.	6



1. 概述

NY9M012A 為單晶片 CMOS 的雙向馬達驅動 IC，利用大型積體電路 (LSI) 製造技術，具有低電源及低成本的特性，可應用於低電壓工作模式。電路採用 H 橋架構，內置功率 MOSFET 開關，可實現對直流電機做 正轉、反轉、煞車、停止 四個功能的控制。

2. 功能

- (1). 寬廣的工作電壓：1.8V ~ 9.6V。
- (2). 內置 PMOS/NMOS 功率開關的 H 橋驅動器。
- (3). 支援 4 種操作模式：正轉 / 反轉 / 剎車 / 停止。
- (4). 低待機電流 (Typ.=0.1uA)。
- (5). 1.2A 以上電流輸出能力。
- (6). 內建過溫保護功能。(TSD, Thermal Shutdown)
- (7). CMOS 輸入，輸入腳內建下拉電阻，無需外加限流電阻。
- (8). 高達 5KV 的人體靜電模式 (HBM) 的 ESD 保護。
- (9). 提供 SOP-8 和 ESOP-8 封裝。

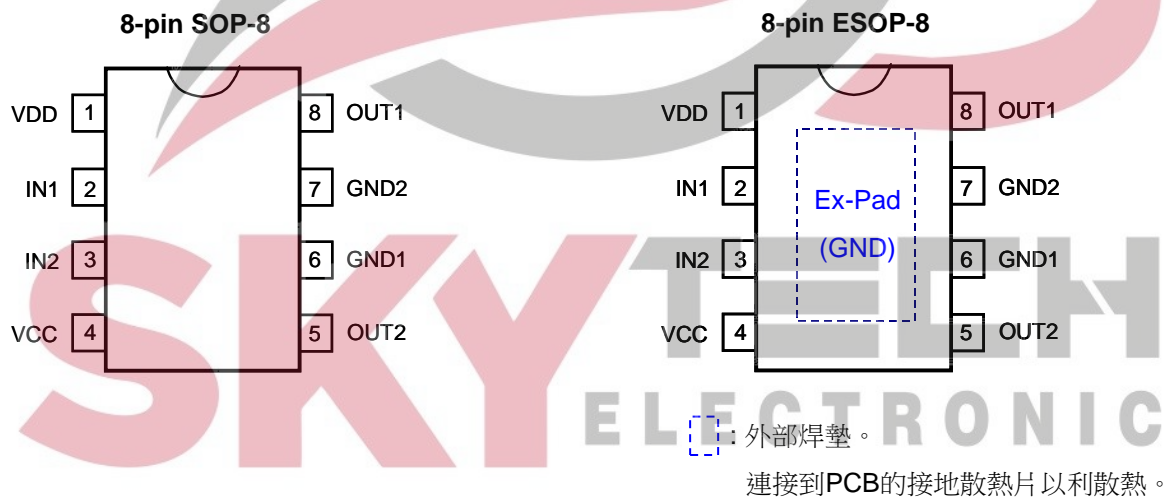

1. GENERAL DESCRIPTION

NY9M012A is a single-chip bi-directional motor driver CMOS IC for low-voltage applications. It is designed by LSI high technology with a low-power and low-cost process. It has H bridge driver of built-in MOSFET power switch to provide Forward / Reverse / Brake / Stop function for motor driver applications.

2. FEATURES

- (1). Wide operating voltage: 1.8V ~ 9.6V.
- (2). H bridge driver of internal PMOS/NMOS power switches.
- (3). Support 4 operating mode: Forward / Backward / Brake / Stop.
- (4). Low standby current. (Typ.=0.1uA)
- (5). Over 1.2A output current capability.
- (6). Built-in Thermal Shutdown (TSD) circuit.
- (7). CMOS input. Built-in input pull-low resistance and no current-limit resistance required.
- (8). High 5KV Human Body Mode (HBM) ESD protection.
- (9). SOP-8 and ESOP-8 package type are available.

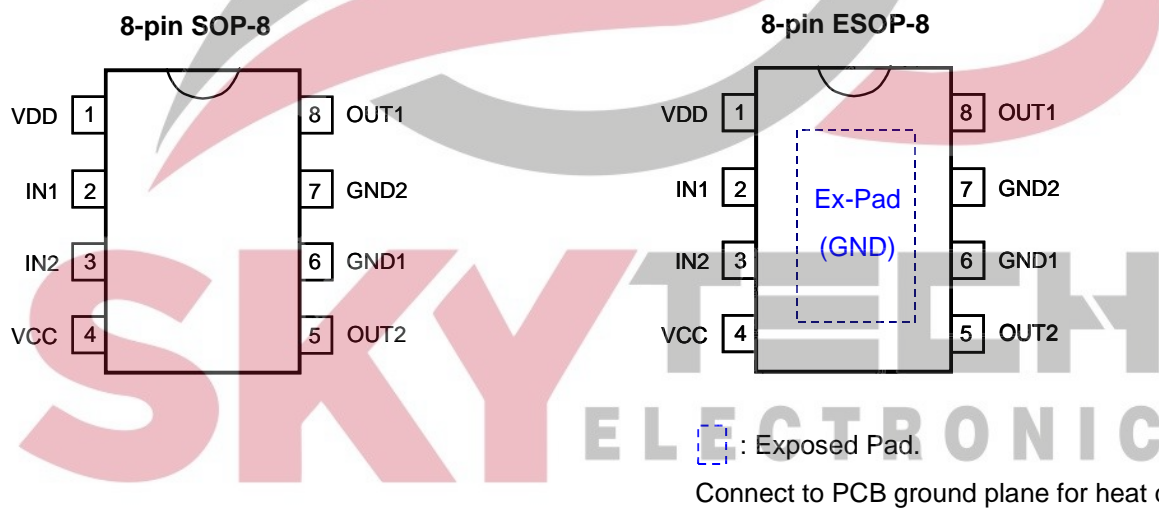

3. BLOCK DIAGRAM

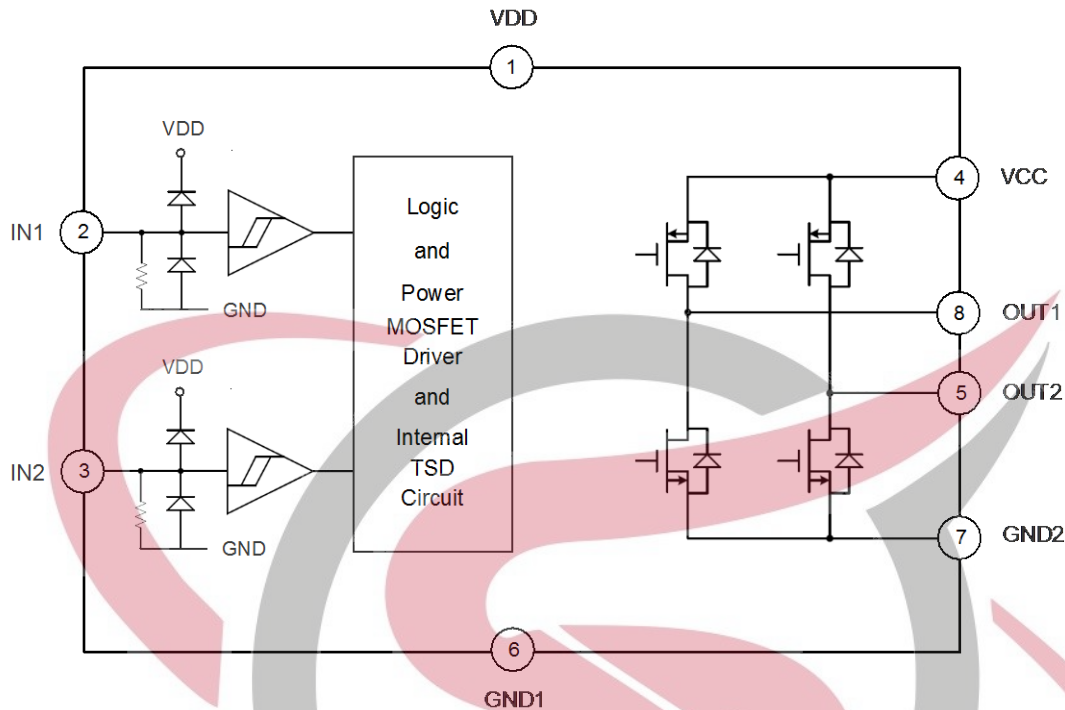

4. PIN DESCRIPTION

Pin Name	Pin No.	ATTR.	Description
IN1	2	I	Forward rotation logic input.
IN2	3	I	Backward rotation logic input.
OUT1	8	O	Forward rotation output.
OUT2	5	O	Backward rotation output.
VDD	1	Power	Positive power of logic control circuit.
VCC	4	Power	Positive power of output power MOSFET.
GND1	6	Power	Negative power of logic control circuit.
GND2	7	Power	Negative power of output power MOSFET.
Ex-Pad	9	Power	Exposed pad for thermal tab, must be connected to GND.

5. FUNCTION DESCRIPTION

IN1	IN2	OUT1	OUT2	Function
0	0	Z (Off)	Z (Off)	Stop (Standby)
1	0	1	0	Forward
0	1	0	1	Backward
1	1	0	0	Brake

6. ELECTRICAL CHARACTERISTICS

6.1 Absolute Maximum Rating

Symbol	Parameter	Rating	Unit	
$V_{DD} - V_{SS}$	Supply voltage of logic control circuit	-0.5 ~ +7.5	V	
V_{CC}	Supply voltage of output power MOSFET	10.0	V	
$I_{OUT-PEAK}$	Output peak current	2.5	A	
θ_{JA}	Thermal resistance (Junction to Ambient)	SOP-8	150	°C/W
		ESOP-8	60	
P_D	Power dissipation	SOP-8	0.9	W
		ESOP-8	2.3	
T_A	Operating ambient temperature	-40 ~ +85	°C	
T_J	Operating junction temperature	+160	°C	
T_{ST}	Storage temperature	-55 ~ +160	°C	

6.2 DC Characteristics ($V_{DD}=3.0V$, $V_{CC}=6.0V$, $T_A=25^\circ C$, unless otherwise specified)

Symbol	Parameter	Min.	Typ.	Max.	Unit	Condition
V_{DD}	Operating voltage (Logic)	1.8		6.8	V	
V_{CC}	Operating voltage (MOSFET)	1.8		9.6	V	
I_{SB}	Standby current		0.1	1	uA	IN1=IN2=0
I_{OP}	Operating current	$V_{DD} = V_{CC} = 3.0V$		180	uA	IN1=1, IN2=0 or IN1=0, IN2=1 or IN1=1, IN2=1
		$V_{DD} = V_{CC} = 6.0V$		260	uA	
I_{IH}	Input high current (12kΩ pull-low resistance)		260		uA	$V_{IH} = 3.0V$
			510		uA	$V_{IH} = 6.0V$
V_{IH}	Input high voltage	2			V	
V_{IL}	Input low voltage			0.8	V	
R_{ON}	Output resistance (SOP-8 Package)		0.38		Ω	$I_{OUT} = 800mA$
			0.42		Ω	$I_{OUT} = 1200mA$
			0.48		Ω	$I_{OUT} = 1500mA$
	Output resistance (ESOP-8 Package)		0.35		Ω	$I_{OUT} = 800mA$
			0.38		Ω	$I_{OUT} = 1200mA$
			0.41		Ω	$I_{OUT} = 1500mA$
I_{OUT}	Output continuous current (* with PCB heat dissipation)		1200	1600*	mA	SOP-8
			1500	1900*	mA	ESOP-8
I_{PULSE}	Pulsed drain current			6.0	A	Pulse width < 20ms
T_{RISE}	Output rise time		310		ns	PWM=20kHz, Duty=50%
T_{FALL}	Output fall time		125		ns	
T_{RP}	Input-to-Output response time		420		ns	
T_{TSD}	Thermal shutdown (TSD)		160		°C	Junction temperature
T_{TSDH}	Thermal shutdown hysteresis		40		°C	

7. APPLICATION CIRCUIT

(1) One Motor Bi-Directional Control (Single Power)

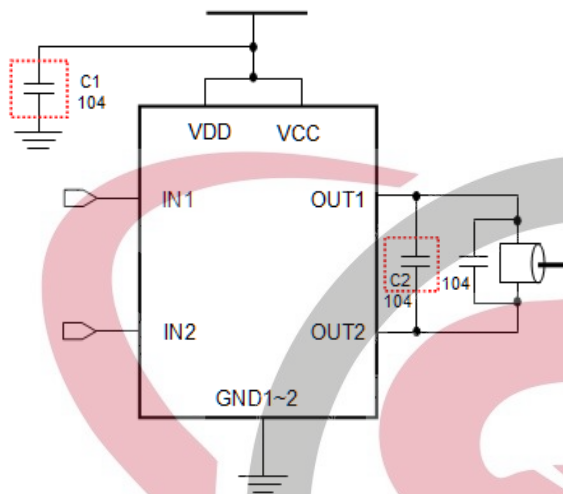

(2) Two Motors Directional Control (Single Power)

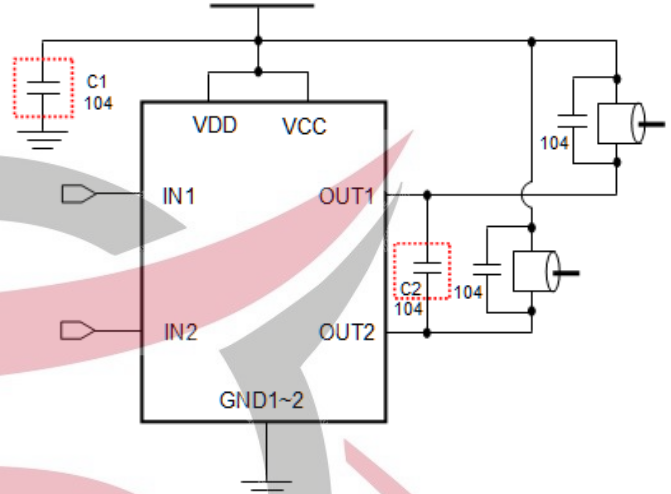

(3) One Motor Bi-Directional Control (Dual Power)

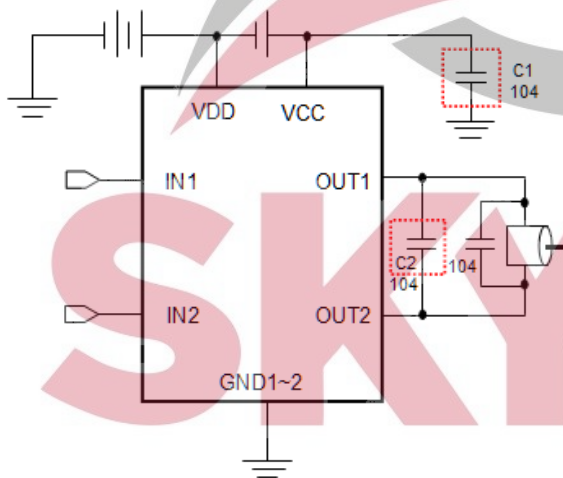

(4) Two Motors Directional Control (Dual Power)

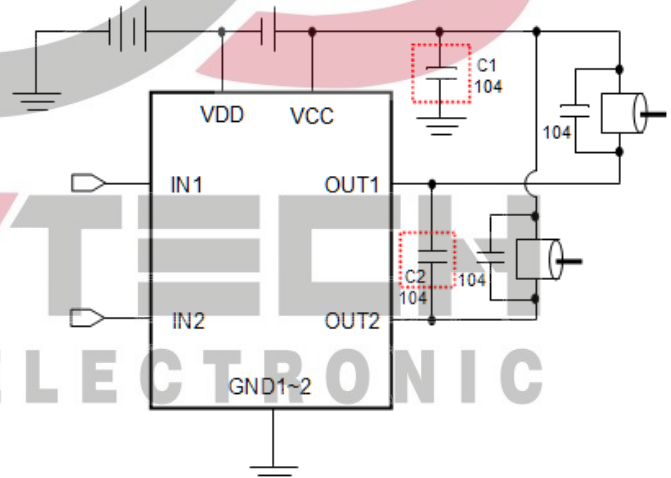

* In normal application, C1 (0.1uF) can be saved, but please reserve C1 space at PCB layout.

* If voltage is higher than 6.0V, C2 (0.1uF) is necessary to endure high voltage.

8. PACKAGE DIMENSION

8.1 8-Pin Plastic SOP (150 mil)

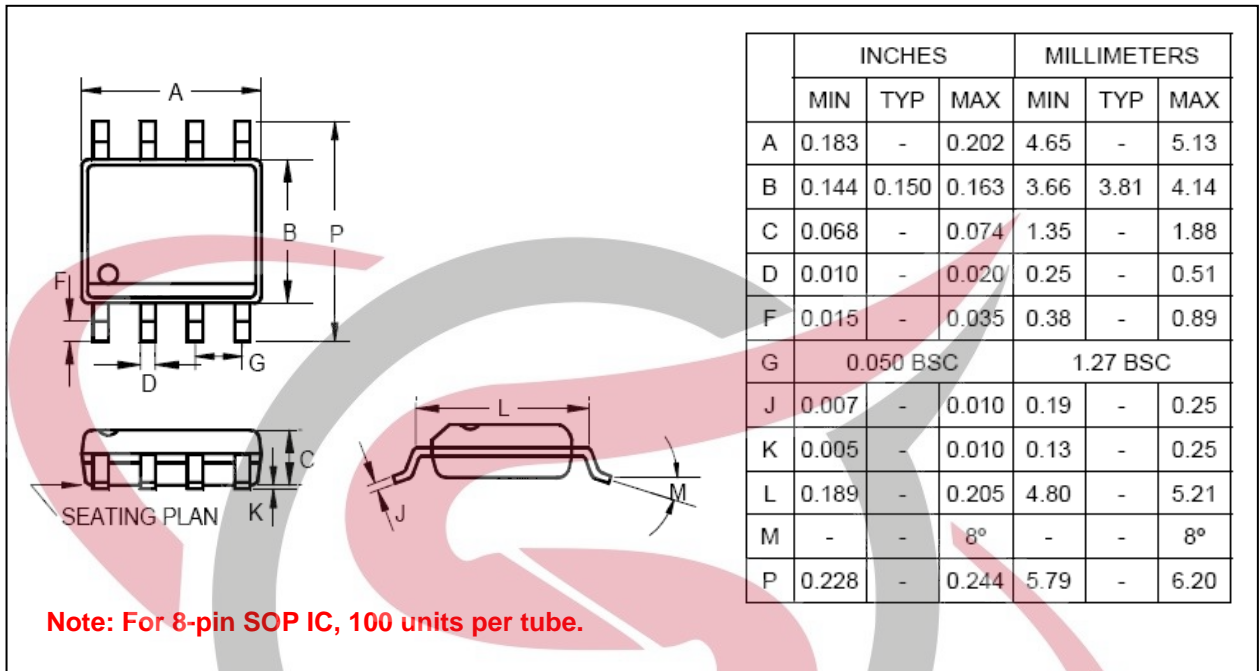

8.2 8-Pin Plastic ESOP with Exposed Pad (150 mil)

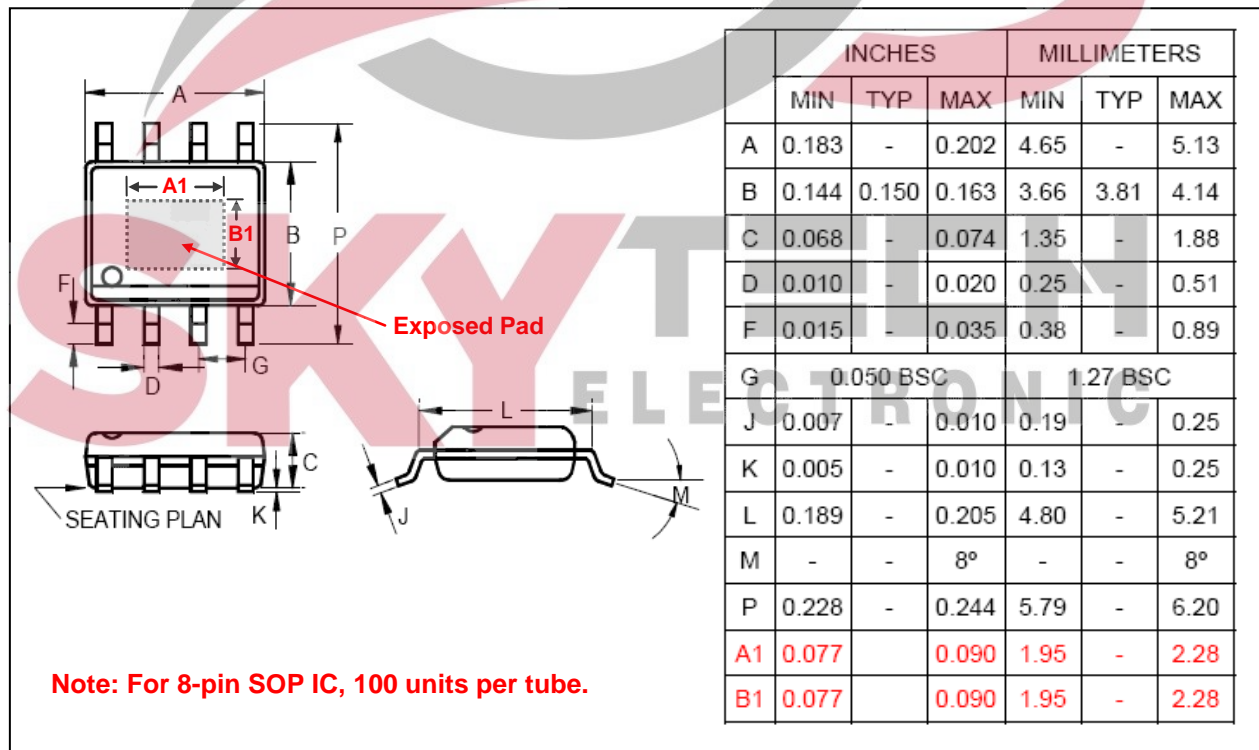

9. ORDERING INFORMATION

<i>P/N</i>	<i>Package Type</i>	<i>Package Width</i>	<i>Shipping</i>
NY9M012AS8	SOP-8	150 mil.	<u>Tape & Reel</u> : 2.5K pcs per Reel <u>Tube</u> : 100 pcs per Tube
NY9M012AE8	ESOP-8	150 mil.	

